



# INSTALLATION INSTRUCTIONS

## 24" BED-SIDE STORAGE BOX #114, #122

Please read and fill out the enclosed warranty registration card to activate your warranty.

### SHIPMENT CONTENTS



Tuffy storage box



(2) Inside Brackets



(2) Outside Brackets



(4) 5/16"-18 Carriage Bolts



(10) 5/16" WASHERS



(8) 5/16 NYLOCK NUTS



(2) 5/16 x 11/4" BOLTS

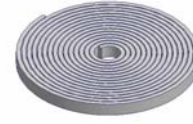

RUBBER SEAL

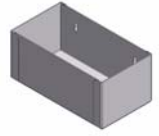

TRAY

### **TOOLS NEEDED**

- Electric drill
- 3/8" Drill bit
- Marker or pencil
- Knife
- 1/2" Socket and ratchet
- 1/2" Wrench
- Silicone sealant (Recommended)

### **PLEASE READ ALL INSTRUCTIONS THOROUGHLY BEFORE STARTING INSTALLATION.**

#### **Pre-installation notes**

1. Since most truck beds can vary between models and brands the Tuffy storage box is designed for a wide variety of mounting options.
2. Check the fit before beginning the installation process.
3. Install the rubber seal on the lid and check the lock operation. (SEE FIGURE 1)
4. Place (2) of the 5/16-18 Carriage Bolts into the slots in each of the (2) Outside Brackets then attach the Inside brackets to the Outside Brackets using 5/16 Nylock Nuts and 5/16 Washers. The hold down tab on the Inside Bracket will prevent the Carriage bolts from spinning during the installation. ONLY SLIGHTLY HAND TIGHTEN THE NUTS AND WASHERS. (HOLE 3 IN FIGURE 2)
5. Place the Tuffy box in the desired mounting spot and mark the locations on the truck bed rail corresponding with holes in the back of the Tuffy box. (HOLE 1 IN FIGURE 2) The marks for the bracket assembly should be spaced 19 5/16" apart center to center.
6. Position the inside brackets and outside brackets to "sandwich" the flange on the inside of the truck bed rail and raise the brackets as high as possible. The bracket assemblies should be centered on the marks made previously on the bed rail. Tighten the 5/16

Nylock Nuts to secure both the brackets to the truck bed rail. (HOLE 3 IN FIGURE 2) While tightening be sure the Hold Down Tab on the Inside Brackets are pressed against the Carriage Bolts.

- Using (2) 5/16 Nylock Nuts, and (2) 5/16" Washers attach each of the (2) mounting bracket assemblies to the corresponding holes in the backside of the Tuffy box. (HOLE 1 AND 2 IN FIGURE 2)
- Mark the truck bed floor through the (2) holes in the bottom of the storage box making sure the box is upright. (SEE FIGURE 3)

***WARNING!***

**Make sure that there is nothing under the vehicle that will be damaged by the drill bit when drilling.**

- Drill out the (2) marked spots with a 3/8" drill bit. (SEE FIGURE 3)
- It is recommended to use silicone sealant in any holes drilled in the vehicle to prevent rusting.
- Install (2) 5/16 x 1 1/4" bolts with (2) 5/16" washers up from underneath through the holes drilled in the bottom of the truck bed. Fasten the bolts with (2) 5/16" washers and (2) 5/16" nylock nuts. (SEE FIGURE 3)
- Check the lock operation.

# ATTENTION:

## ***FREQUENT LUBRICATION IS NECESSARY ON THE LOCKING SYSTEM***

The pushbutton lock contains an "O" ring seal to protect the interior from dust and water. If this mechanism is not lubricated regularly it will become difficult to operate and it may not return to its home position preventing the key from operating the lock. If this happens simply pull up on the pushbutton to manually bring it back to its home position. Lubricate the pushbutton with a light lubricant such as silicone spray. The pushbutton may have to be periodically disassembled and cleaned.

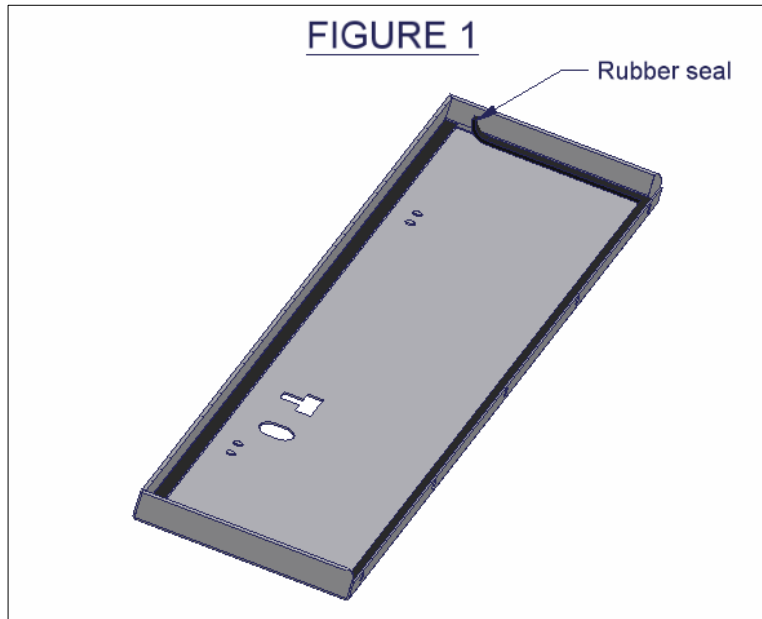

**FIGURE 2**

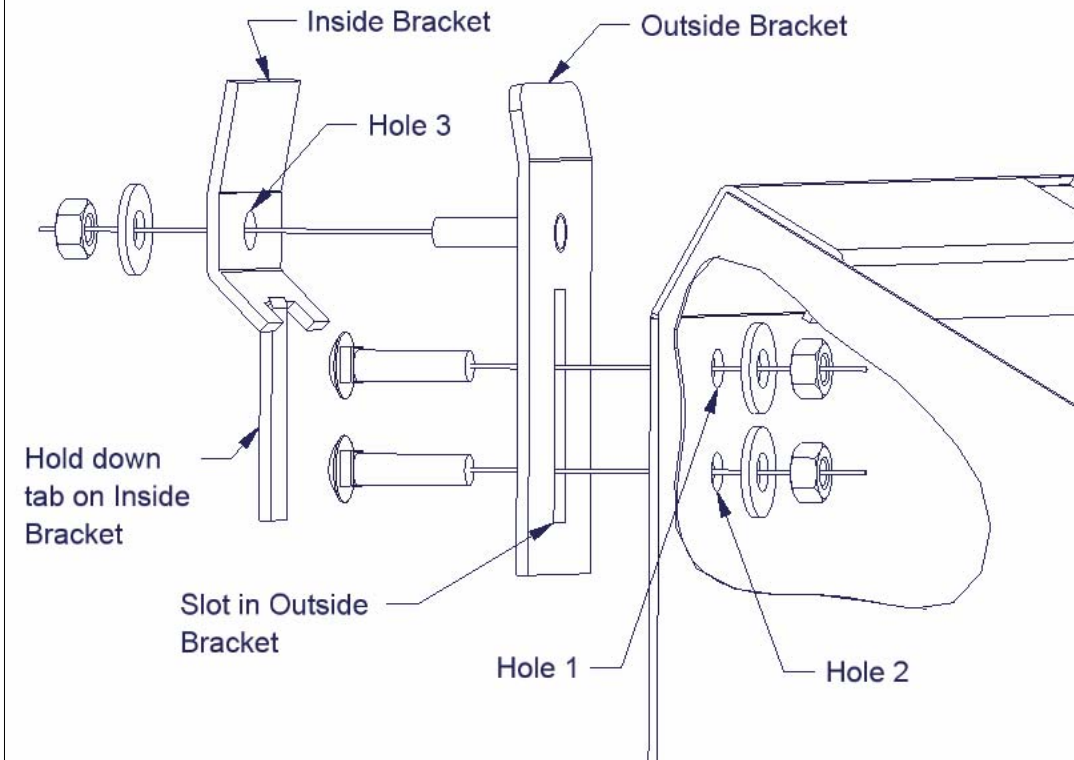

**FIGURE 3**

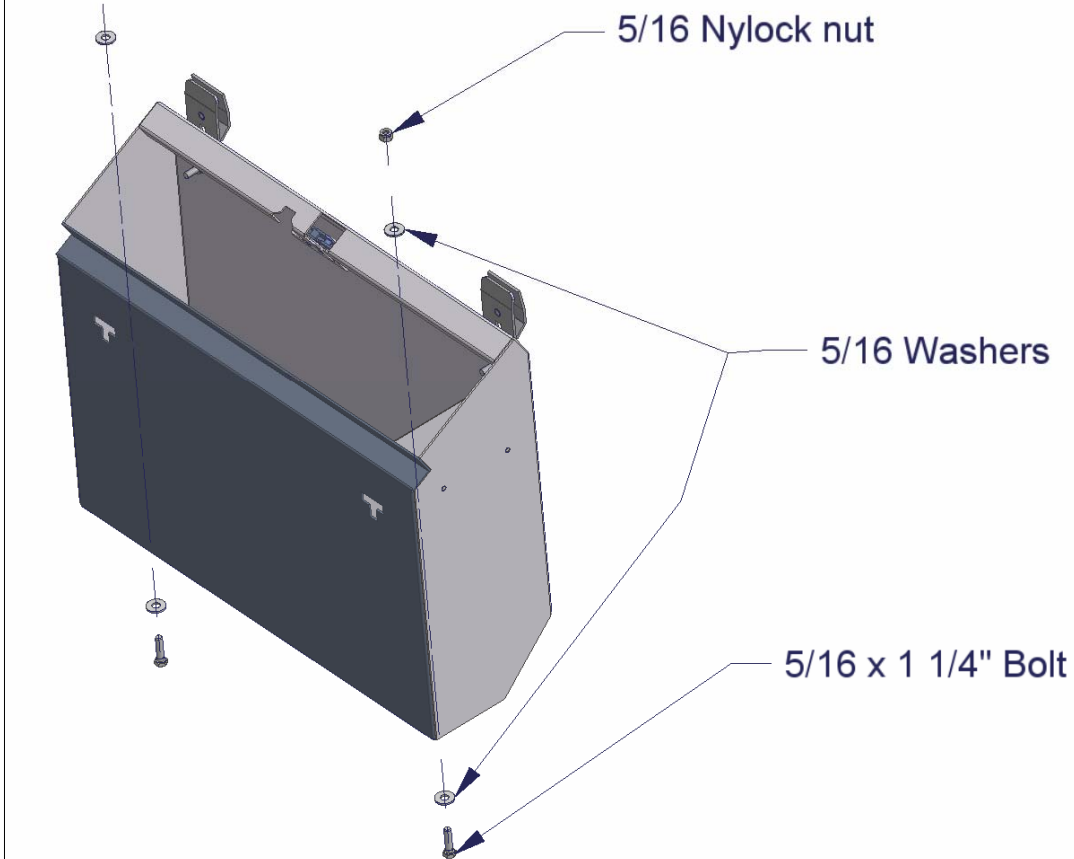

Call (970) 564-1762 for Technical Support